



110
010
ZOOMGATE

SPEED

SPEED ARM GATE SYSTEM

The **SPEED** Gate System is a security gate with a fast moving barrier arm that controls human traffic. Its' aesthetic design and small footprint coalesces with its' surroundings seamlessly. The option of deploying a barrier or a barrier-free security lane provides the freedom and flexibility to cater to various situations.

Safety Features

Each lane is fitted with safety beams to ensure proper access clearing. Options to cater to children and wheelchair users are available.

Our modern motor mechanism will disengage the gate when the gate is obstructed from movement. The use of tampered glass or acrylic provides an additional safety feature for the users.

Aesthetic

A variety of customisation, different finishes and colours of the stainless steel is available, further providing designers the freedom to seamlessly integrate the products into any architecture environment as they desire. Mild steel powder-coating into a variety of colours is also available.

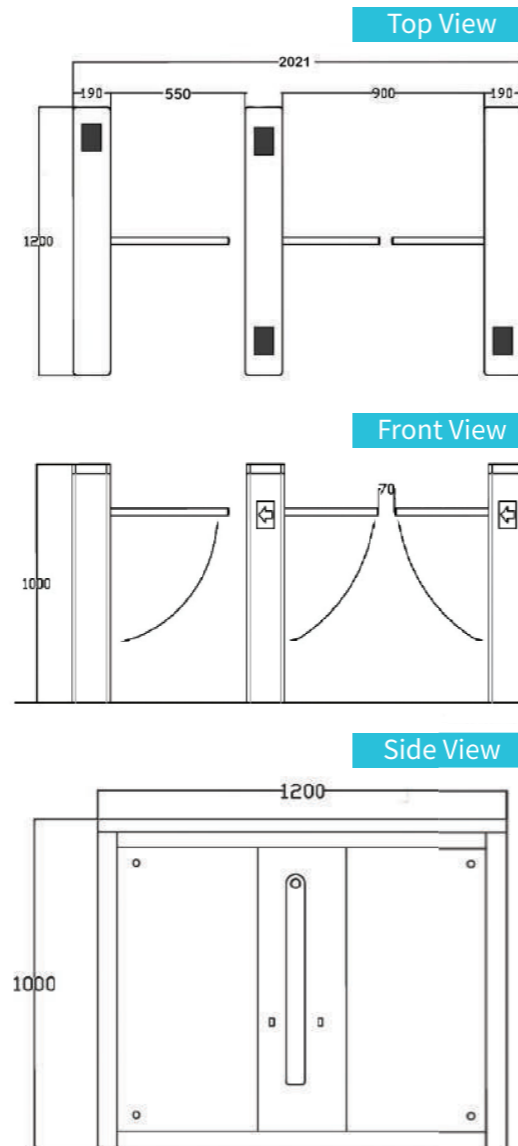

ADA-AR-01



Dimension	Console height	1000mm
	Console length	1200mm
	Console width	190mm
	Passage width	550 / (900 Handicap) mm
Operation	Adjustable cycle time	0.5 - 0.8 sec
Electical	Input voltage (AC)	230V 50Hz
	Operating voltage (rated)	Typical 0.5A
	Inrush	1.5A
Add-ons	Tail-gate sensor	
	Crawl Sensor	
	LED Sensor	
	Reader Mounting	

*These Dimensions are for Illustration Purposes, Actual Figures are Subject to Change.

Colour: Bronze Black Champagne Silver

Finishing: Hairline Non Directional

Other designs you may like:



WING
Flap Gate System



SWING
Swing Gate System



TRI
Tripod Gate System



MAX
Turnstile Gate System



ZOOM TECH

Zoom Tech Pte Ltd, 68 Senoko Road, Singapore 758128
T +65 6365 4715 or +65 6755 3306 | F +65 6482 3395
www.zoomtech.com.sg